

Raychem CS-150-XX-PI

COLD APPLIED CONNECTION AND SPLICE KIT WITH SILICONE SEALING FOR POLYMER INSULATED (PI) HEATING CABLES

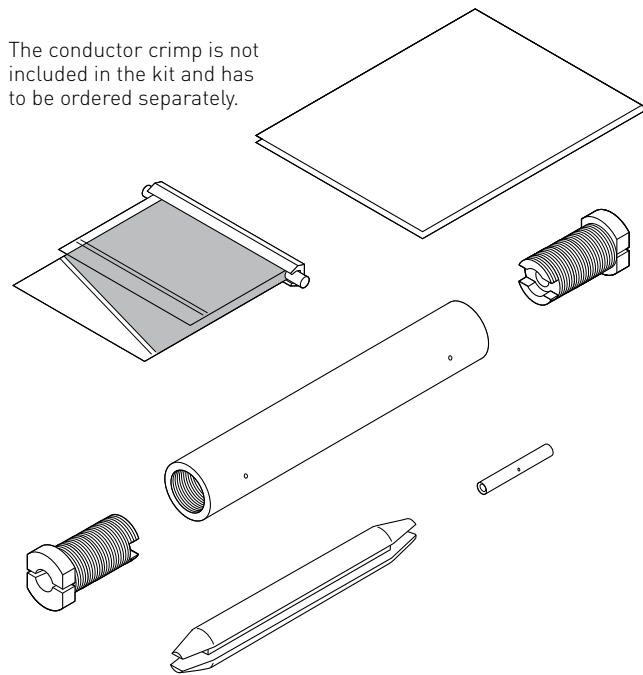

The conductor crimp is not included in the kit and has to be ordered separately.

The kits CS-150-xx-PI are designed to connect a PI cold lead cable to a polymer insulated (PI) series heating cable as well as to splice two PI heating cables. The kit employs a two component silicone compound to provide durable and flexible moisture proof encapsulation.

Electrical continuation is maintained via specially engineered crimps that provide a highly reliable electrical connection.

It is very important that the electrical crimp connections are performed with the correct crimp tool (PI-TOOL-xx).

Due to its low profile design, the connection can be easily installed under the insulation directly on the pipe. If used as a connection kit, a cable gland, an insulation entry kit as well as a crimp for the connection between the cold lead and the heating cable, need to be ordered separately. If used as a splice kit, just the heating cable conductor crimp is needed additionally.

For simplified installation- and maintenance work, we offer a crimp toolbox that contains the suitable installation tool, crimping dies and a variety of crimps exactly matching common cable types. For all details concerning the crimping system, refer to the datasheet of the electrical connection system for PI heating cables (PI-TOOL-SET-xx).

APPLICATION

Cold applied silicone sealed connection/splice for PI heating cables.

KIT CONTENTS

1 x PTFE body
 2 x PTFE plugs
 1 x PTFE crimp separator
 1 x two component silicone compound in plastic bag (shelf life is 12 months)
 1 x identification label
 1 x multilingual installation instruction

APPROVALS

PTB 08 ATEX 1101 U
 II 2G Ex e II / II 2D EX tD A21 IP65
 IECEx PTB 08.0050U
 Ex e II 2G Ex e II / Ex tD A21 IP65
 TC RU C-BE.ME92.B.00056



DIMENSIONS

CS-150-2.5-PI: Overall length ~120 mm, Ø ~17 mm
 CS-150-6-PI: Overall length ~120 mm, Ø ~26 mm
 CS-150-25-PI: Overall length ~135 mm, Ø ~35 mm

CS-150-XX-PI

TECHNICAL DATA	CS-150-2.5-PI	CS-150-6-PI	CS-150-25-PI
Max. operating temperature	200°C continuous, (260°C intermittent)		
Max. operating voltage	450 Vac nominal		
Max. operating current	Only limited by heating cable used		
Cable/Cold leads	Up to 2.5 mm ²	4 to 6 mm ²	10 to 25 mm ²
ORDERING DETAILS			
Order reference	CS-150-2.5-PI	CS-150-6-PI	CS-150-25-PI
Part number (Weight)	1244-000586 (0.1 kg)	1244-000588 (0.2 kg)	1244-000587 (0.3 kg)
ACCESSORIES			
Cable gland for connection kit	GL-44-M20-KIT (one piece per cold lead connection; to be ordered separately)		



WWW.PENTAIRTHERMAL.COM

EUROPE, MIDDLE EAST, AFRICA

Tel: +32.16.213.511
Fax: +32.16.213.603
thermal.info@pentair.com

UNITED KINGDOM

Tel: 0800 969 013
Fax: 0800 968 6241
salesthermaluk@pentair.com

IRELAND

Tel: 1800 654 241
Fax: 1800 654 240
salesie@pentair.com

Pentair is owned by Pentair or its global affiliates. All other trademarks are the property of their respective owners. Pentair reserves the right to change specifications without prior notice.

© 1998-2016 Pentair.